

VERTICAL SIDE CABLE ORGANIZER TYPE 2

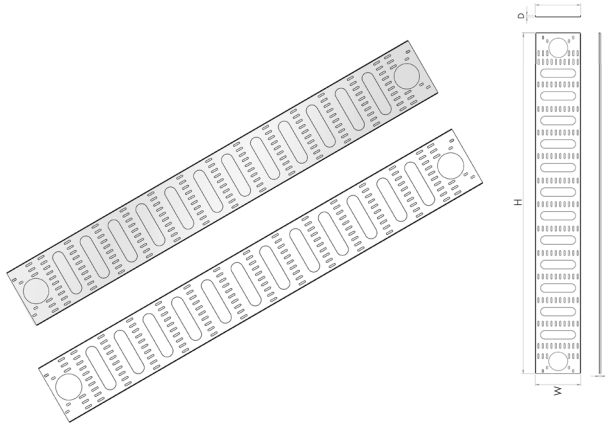

Material	1,5 mm Steel
Color	RAL 7035 and RAL 9005
Finish	Electrostatic Powder Paint
Packaging	Two pieces in a box

H (U)	H (mm)	D (mm)	W (mm)	Weight (kg)	Part No
26U	1246	8	260	6,0	CCA-X-5017
32U	1510	8	260	7,2	CCA-X-5018
36U	1686	8	260	8,0	CCA-X-5019
39U	1820	8	260	8,9	CCA-X-5020
42U	1950	8	260	9,0	CCA-X-5021
47U	2170	8	260	10,8	CCA-X-5022

MODULAR ADJUSTABLE VERTICAL CABLE ORGANIZER TYPE 1

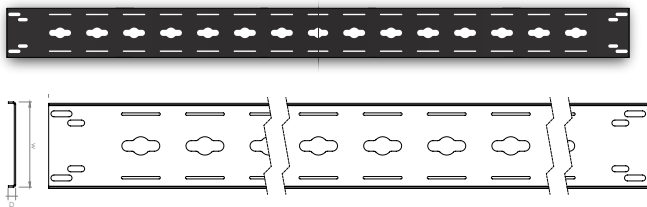

Material	1,5 mm Steel
Color	RAL 7035 and RAL 9005
Finish	Electrostatic Powder Paint
Packaging	One piece in a box
Module Capacity	42U (max. 26 pcs) 47U (max. 29 pcs) * Cable management hooks

H (U)	D (mm)	W (mm)	Weight (kg)	Part No
42U	13	90	2,83	CCA-X-5023
47U	13	90	3,17	CCA-X-5024

CABLE MANAGEMENT HOOKS



Material	1,5 mm Steel
Color	RAL 7035 and RAL 9005
Finish	Electrostatic Powder Paint
Packaging	One piece in a box
Module Capacity	42U (max. 26 pcs) 47U (max. 29 pcs)

H (mm)	D (mm)	W (mm)	Weight (kg)	Part No
50	70	84	0,42	CCA-X-5025

FRONT & REAR ORGANIZER

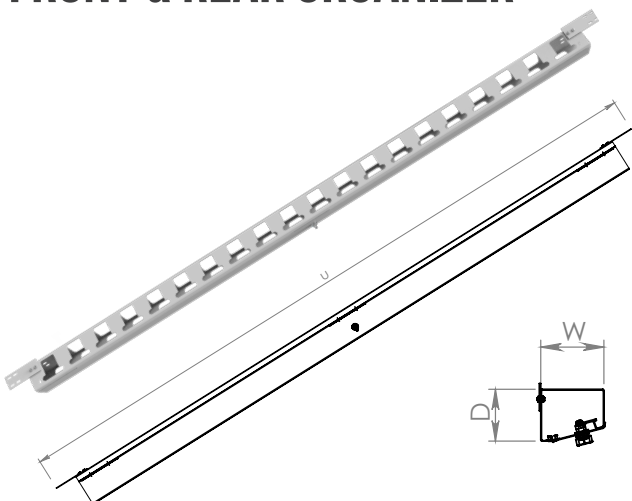

Material	1 mm Steel
Color	RAL 7035 and RAL 9005
Finish	Electrostatic Powder Paint
Packaging	Two pieces in a box

H (mm)	D (mm)	W (mm)	Weight (kg)	Part No
26U	92	100	7,6	CCA-X-5005
32U	92	100	8,2	CCA-X-5006
36U	92	100	9,4	CCA-X-5007
39U	92	100	10,2	CCA-X-5008
42U	92	100	11	CCA-X-5009
47U	92	100	12,4	CCA-X-5010

**Only for 800mm width cabinets

X (Color code): 7:RAL 7035 Light Grey, 9:RAL 9005 Black